

Grand Speed Optimal Quality



Making Industry Smarter!

New Benchmark for Both **Speed & Quality.**

G2-TEX High Speed Textile Industrial Digital Printer, redefines textile printing speed and quality. Adhering to DPI's ergonomic design, keep it durable and easy to operate.

DPI unique ink system is compatible with reactive, acid, disperse, pigment inks, etc.

With flexible adaptation to multiple width specifications from our exquisite technology,

DPI provides efficient and diverse solutions for textile digital printing beyond past experience.

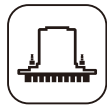

Up To
48 Print Heads



Up to 12
Color Channels

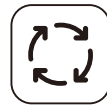

Full-circulation
Ink System



Compatible with
Multiple Ink Solutions

Applicable Fabrics: All types of natural fibers, artificial fibers, nylon, and chemical fibers, etc.



Features

- Supports flexible configuration of multiple print heads, covering multi-color channels and mainstream printing widths.
- Equipped with multiple anti-fabric-overlapping and safety devices to fully protect print heads and equipment safety.
- Full-circulation ink system and individual temperature control system, automatic adjustment according to ambient and print head temperatures.
- Equipped with stretching, centering and constant tension devices, applicable to various textile fabrics, like knitted and woven fabrics.
- Belt Washing System featuring an dual sink design, ensuring the belt cleaned without residue.

Ink Types	
Reactive Ink	✓
Acid Ink	✓
Disperse Ink	✓
Pigment Ink	✓
Fabrics	
Natural Fibers	✓
Artificial Fibers	✓
Nylon	✓
Chemical Fibers	✓

*For more details, please contact DPI



A Fabrics Feeding System

Segmented (detachable) feeding system enabling convenient transport & Installation. Multi-purpose fabric feeding structure, integrating fabric stretching, centering, and constant-tension control devices. Widely adapted to various textile fabrics, including knitted and woven fabrics. Dancing press roller with a heating function, it also has both continuously compensated stepping and continuous movement capabilities, ensuring operational stability. Supports flexible switching between large and small roll sizes, comprehensively meeting diverse production scenarios.

B Scalable To Various Application Scenarios

G2-TEX offers a printing width ranging from 2000 mm - 3400 mm, flexibly catering to diverse production needs. Configured with up to 48 print heads and supports 8/12 color channels, accurately reproducing rich colors. With its full-circulation ink system, it is compatible with various inks such as reactive, acid, disperse, and pigment inks, and suitable for different textile fabrics.

C Uniform Drying Process

Through a symmetrical cyclic air duct design and a precise temperature control system, the temperature deviation in each area inside the oven is controlled within an extremely small range. This ensures that the textile fabrics are heated uniformly and stably during process steps such as drying and color fixing, effectively avoiding problems such as uneven fabric color and performance damage caused by excessively high or low local temperatures.

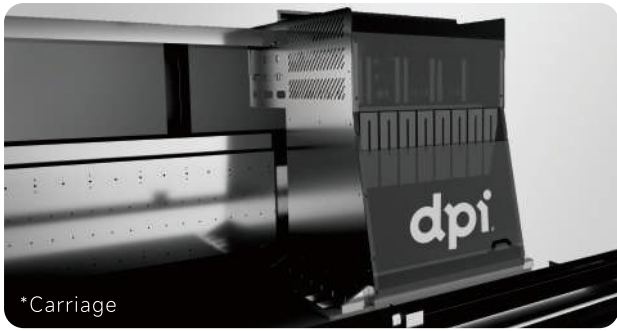

*Carriage



*Multiple Protection Devices

Print Heads & Ink Supply System

- Supports multi-specification printing widths, adapting to more production scenarios.
- Full-circulation ink system with automatic standby circulation, effectively preventing print head drying.
- Independent temperature control system automatically adjust print head temps to achieve stable jetting performance.
- Supports control nozzle voltage adjustment divisional to achieve stable and consistent jetting volume.
- Equipped with the defoaming device, avoiding discontinuous ink ejection & breakage due bubbles in the ink.

Abundant Colors Solution

- Abundant ink solution options, supporting flexible multi-color configurations, deliver prints with delicate gradient color and brilliant rich color.

Multiple Protection Devices

- Anti-crash devices with an extra layer of protection on the carriage to protect the print head against crash more effectively.

Software & Electronic Control

- Self-developed mother board and printhead control system.
- Precision waveform setting to achieve stable jetting capacity.
- High-precision printing belt control, precisely control step transmission to ensure printing accuracy.
- Integrated unique feathering mode, customized feathering settings to eliminate the overlap issues.

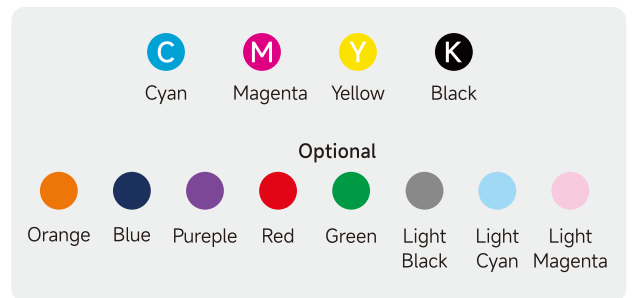



*G2-TEX

Inline Fabrics Feeding System

- Compatible feeding system with optional single/multi-roll unwinding racks for jumbo/small rolls.
- Equipped with stretching, centering and constant tension devices, suitable for knit and woven fabrics.
- Dancing press roller with heating function to soften fabrics and reduce wrinkles.
- Segmented (detachable) feeding system enabling convenient transport & installation.

Intelligent Touch for Easy Operation

- Manual / automatic dual operation functions, one-click start operation.
- Flexible queues management for continuous printing, unattended production
- Front & rear operation touch screens with interlock protection: easier and safer operation
- One - click print button to simplify sample printing.
- Real-time display of printing progress, convenient for management.

High-Efficiency Heating Room

- Symmetrical circulating air duct design, supporting single-layer or multi-layer fabric threading modes.
- Multiple heating methods: electricity, natural gas, thermal oil, steam, etc.
- Adapts multi-section heating room design, flexibly adaptable and configurable as production needs.

Belt Washing System

- Features a dual sink design, supporting separate water inflow and drainage.
- Equipped with double brush rollers, sponge rollers, air blade, water-absorbing rollers and drying system, effectively ensures the cleanness of the belt.
- The scraper can flexibly adjust the angle according to the actual cleaning effects.

Mechanical Structure

- Specialized steel beam structure design minimizes beam deformation risks.
- High-performance belts and transmission components with high-standard materials to ensure steadiness of machine body.
- Long-frame modular design, a longer belt than competitors stabilizes knitted fabric separation from the belt during unwinding.

Specification

Inline Integrated Fabrics Feeding System
 A-Frame Rack Optional
 · Inline integrated fabric feeding
 · External auxiliary fabric feeding with A-Frame rack

Fabrics Winding System
 · Folding Plaiter
 · Surface winding
 · Pneumatic shaft rewinding

Heating Room
 · Industrial heating room (1-3 layers).
 · Symmetrical circulating air duct design,
 · Multiple heating methods: Electricity, Natural gas, Thermal oil, Steam.

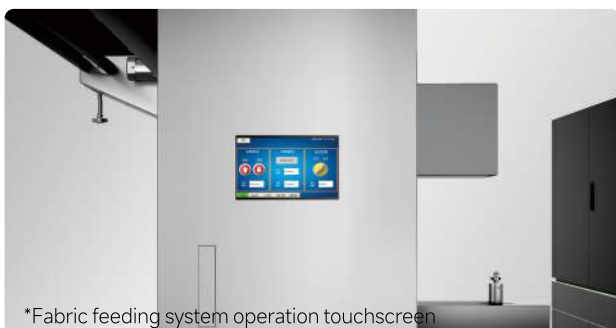

*Fabric feeding system operation touchscreen



*Belt washing system

Technical Data

Model	G2-32	G2-48	G2 L-32	G2 L-48	G2 XL-32	G2 XL-48
Print head	Kyocera KJ4B-EX600					
Max printing width	2000 mm		2600 mm		3400 mm	
No. of print head	32-48					
Colors channel	8-12					
Resolution	600~2400 dpi					
Drop size	5~16 pL					
Height of platform	980 mm					
Air	0.6 Mpa					
Power supply	Three phase 5 wires 380V					
Power	30 KW					
Dimension (L×W×H)	5000×5850×2350 mm		5000×6450×2350 mm		5000×7250×2350 mm	
Weight	8,000 kg		9,000 kg		10,000 kg	

Based on 1800 mm printing width

		G2-32 (4×8)	G2-48 (4×12)
Resolution (dpi)	No. of printing pass	Printing speed @m/h	Printing speed @m/h
400×600	1	600	540
400×1200	2	330	297
508×600	1	521	470
508×1200	2	278	250
600×600	1	448	404
600×1200	2	232	209

Based on 2600 mm printing width

		G2 L-32 (4×8)	G2 L-48 (4×12)
Resolution (dpi)	No. of printing pass	Printing speed @m/h	Printing speed @m/h
400×600	1	504	453
400×1200	2	277	249
508×600	1	448	404
508×1200	2	239	215
600×600	1	385	346
600×1200	2	199	179

Based on 3200 mm printing width

		G2 XL-32 (4×8)	G2 XL-48 (4×12)
Resolution (dpi)	No. of printing pass	Printing speed @m/h	Printing speed @m/h
400×600	1	463	416
400×1200	2	254	229
508×600	1	390	350
508×1200	2	210	210
600×600	1	340	340
600×1200	2	177	167

*Bidirectional printing speed is for reference only; actual speed depends on on-site production performance. Specifications are subject to change due to upgrades, without prior notice.

G2-TEX Layout

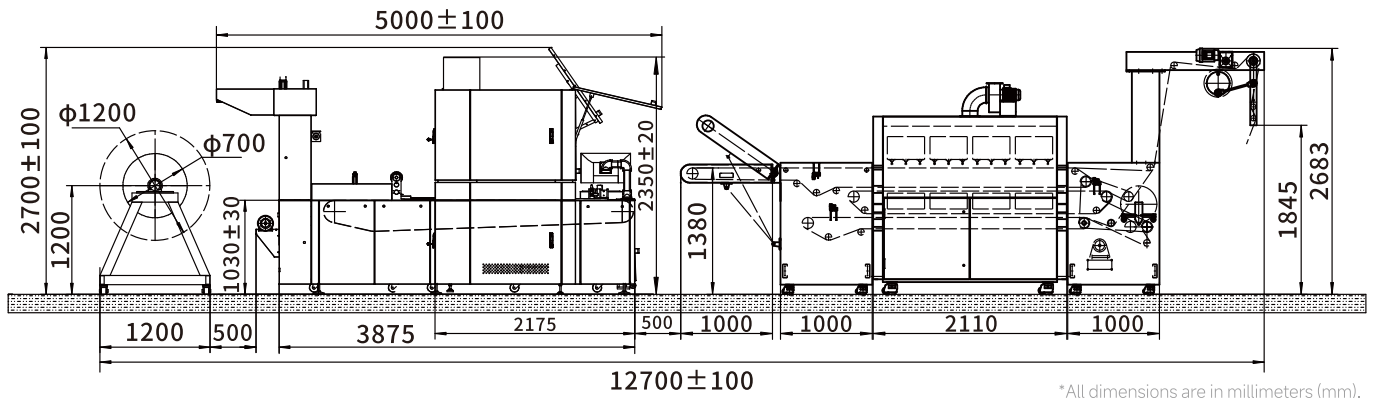

*All dimensions are in millimeters (mm).
Dimensions are for reference only; actual size per product.



*8-12 Colors / 32-64 Print heads
*Additional colors available for customization

4 Rows / 8 Colors

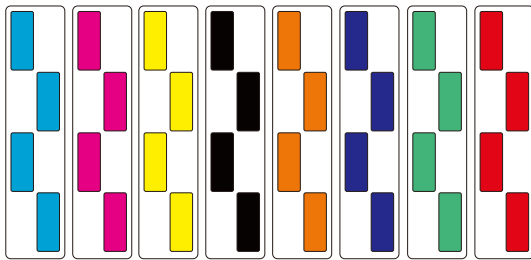

4 Rows / 12 Colors

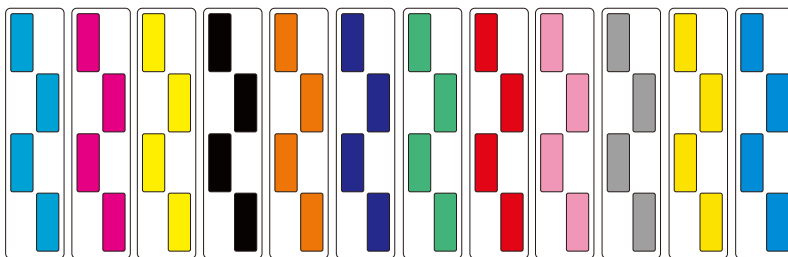

Making Industry Smarter!

DPI is a global technology enterprise, specializes in the R&D, manufacturing, sales, and service of high-speed industrial digital inkjet printers. DPI delivers innovative digital printing solutions to diverse industries such as ceramics, building materials, textiles, and packaging. For more information, please visit www.dpi-t.com

